

Q.6.a:

Convert the following step ladder diagram into ladder logic:

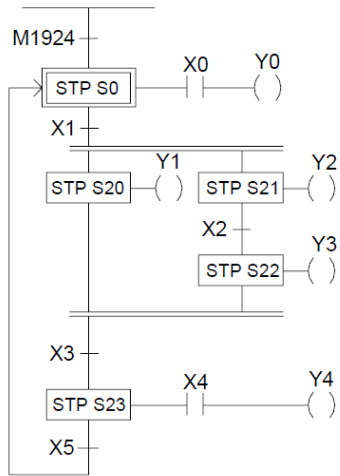

• RESULT:

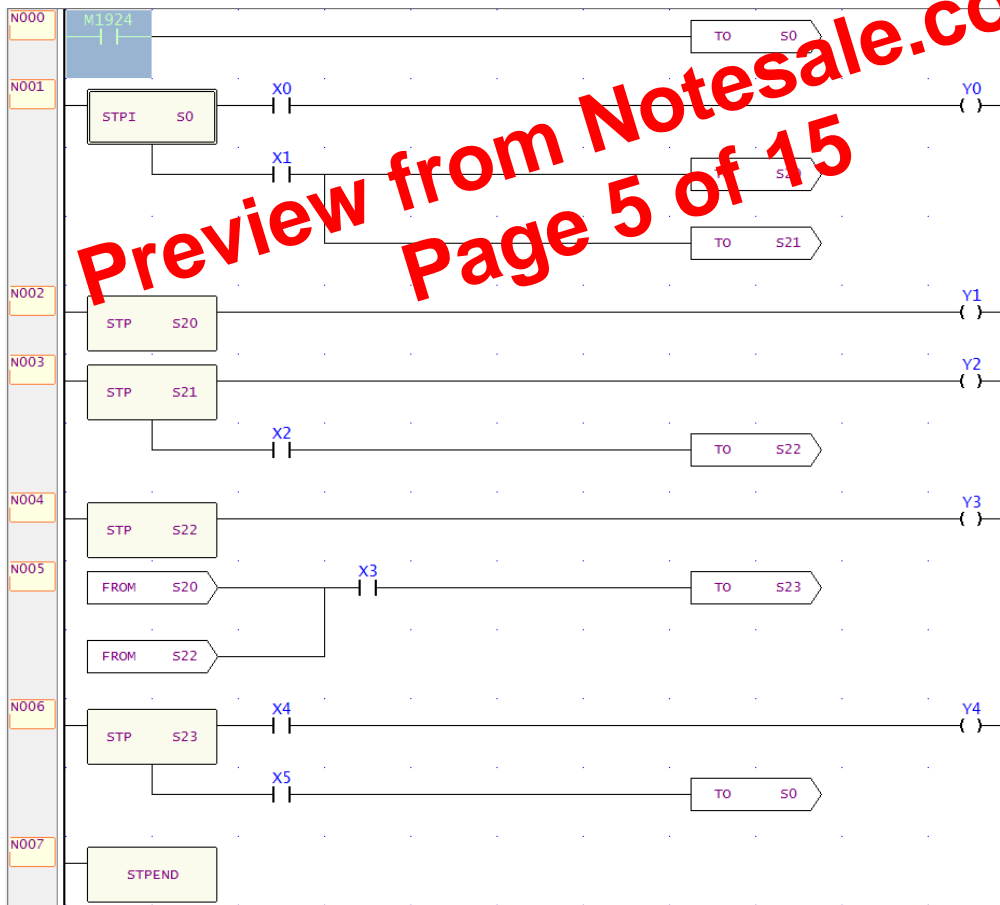

Preview from Notesale.co.uk  
Page 5 of 15

Q.8.a:

Show the schematic of ladder logic control of traffic signal in the space below. Use the following step logic diagram:

