

Example

Write KVL for the loops identified in the circuit below

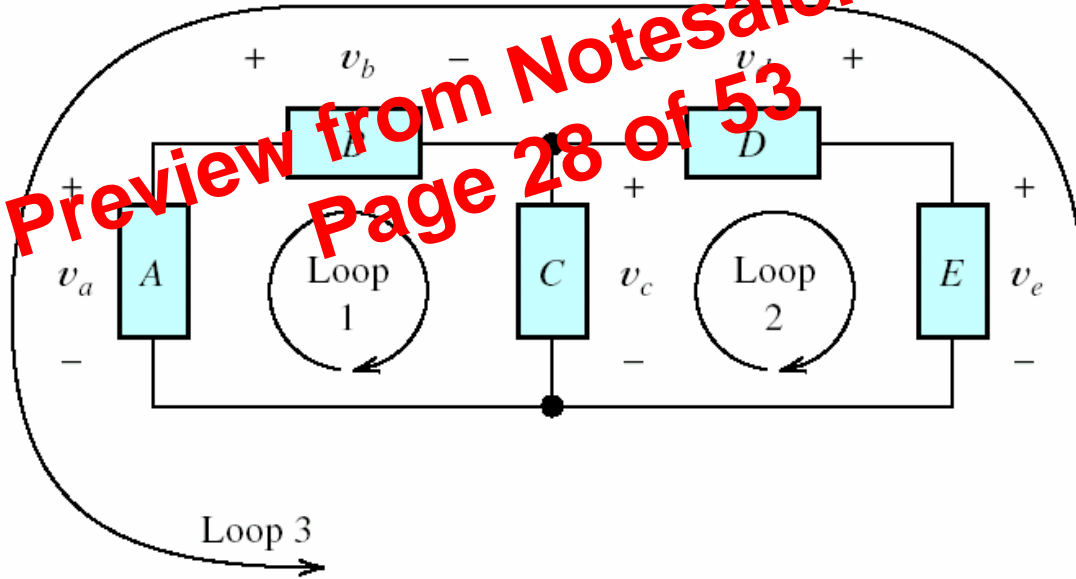

Figure 1.24 Circuit used for illustration of Kirchhoff's voltage law.

$$\text{Loop 1: } -v_a + v_b + v_c = 0$$

$$\text{Loop 2: } -v_c - v_d + v_e = 0$$

$$\text{Loop 3: } v_a - v_e + v_d - v_b = 0$$

Independent Current Sources

- Forces a specific current to flow through itself independent of the elements connected to it and of the voltage across it

Preview from Notesale.co.uk
Page 36 of 53

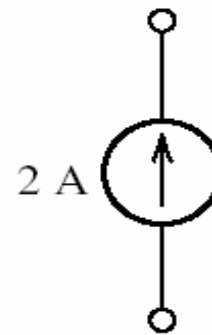
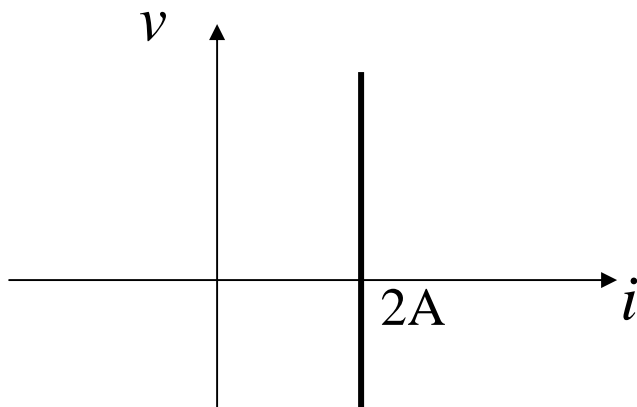

(a) Dc current source

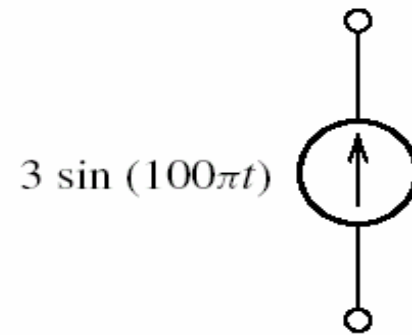

(b) Ac current source

Some Practical Resistors

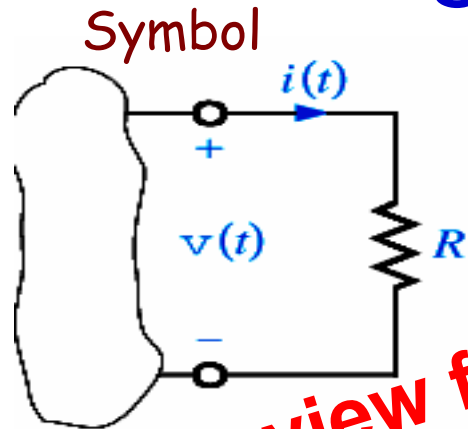

Preview from Notesale.co.uk
Page 40 of 53

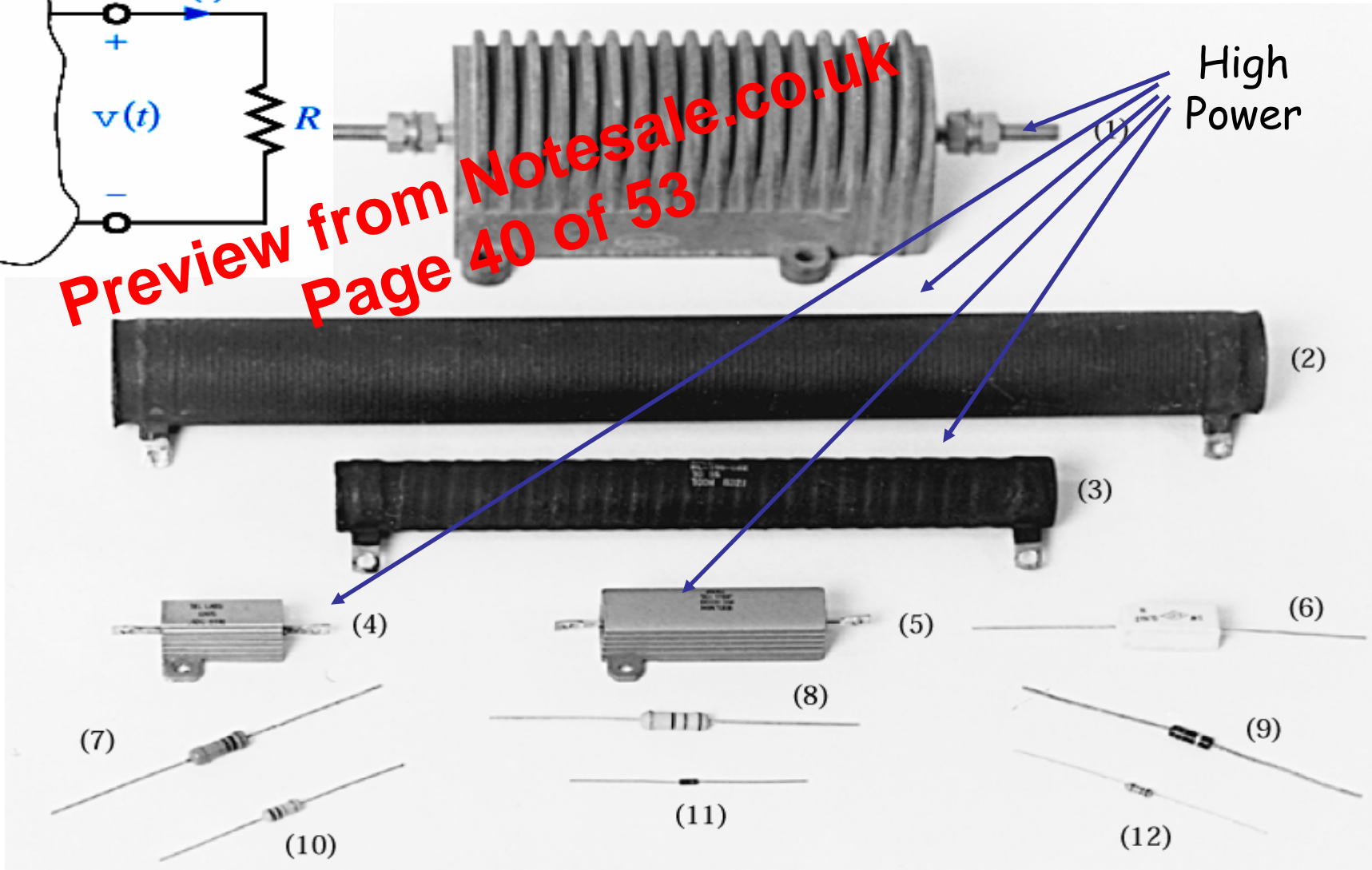

Using KVL, KCL, and Ohm's Law to Solve a Circuit Problem

Example:

Find the source voltage in the following circuit

Preview from Notesale.co.uk
Page 46 of 53

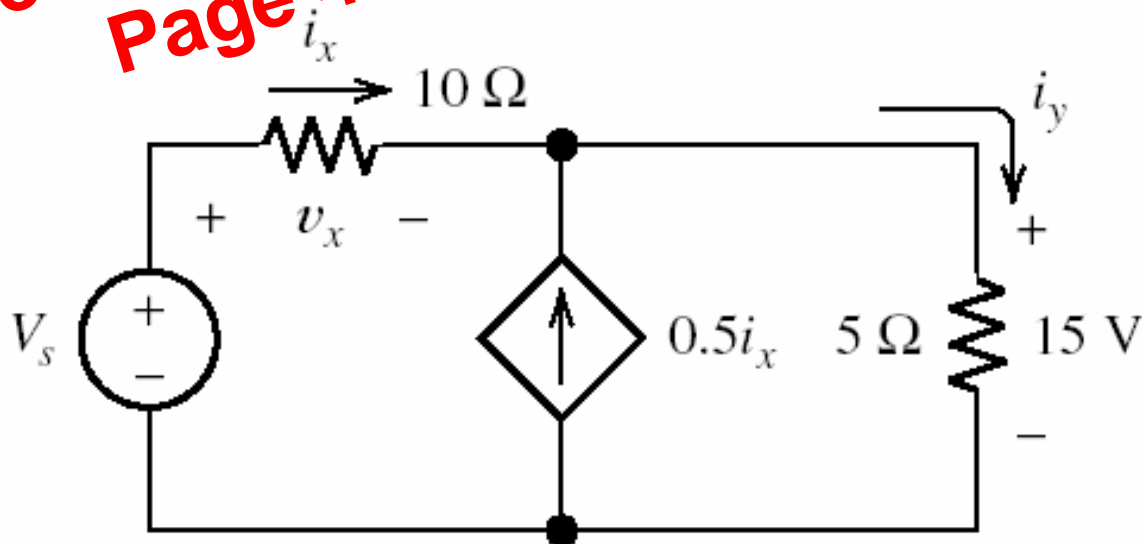

Example (cont.)

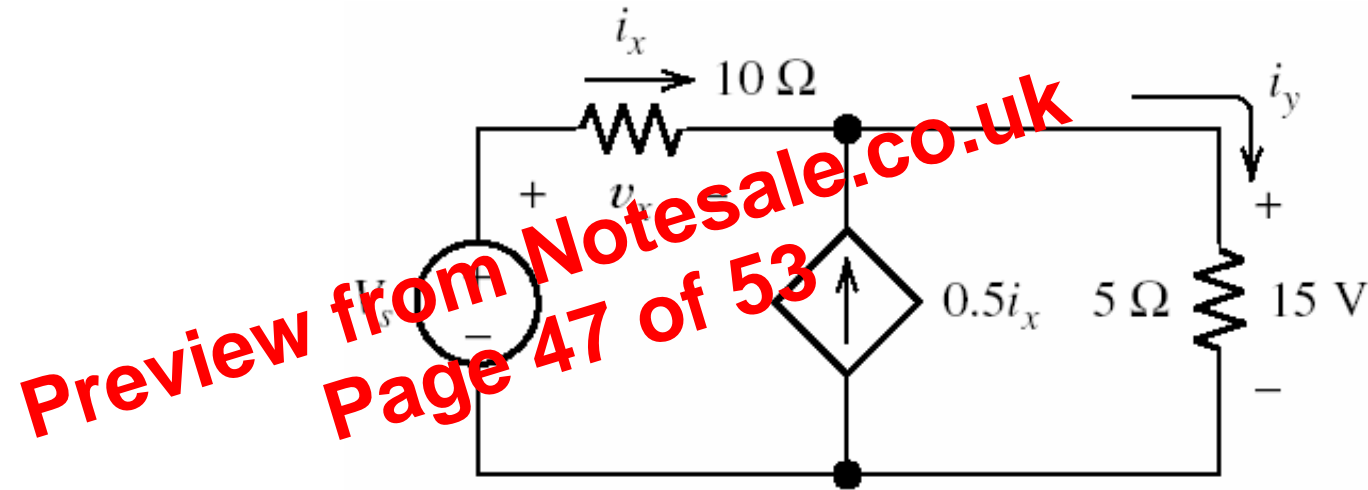

$$i_y = \frac{15 \text{ V}}{5 \Omega} = 3 \text{ A}$$

$$i_x + 0.5i_x = i_y$$

$$i_x = 2 \text{ A}$$

$$v_x = 10i_x = 20 \text{ V}$$

$$V_s = v_x + 15$$

$$V_s = 35 \text{ V}$$



Another Example

Find V_x

Preview from Notesale.co.uk
Page 48 of 53

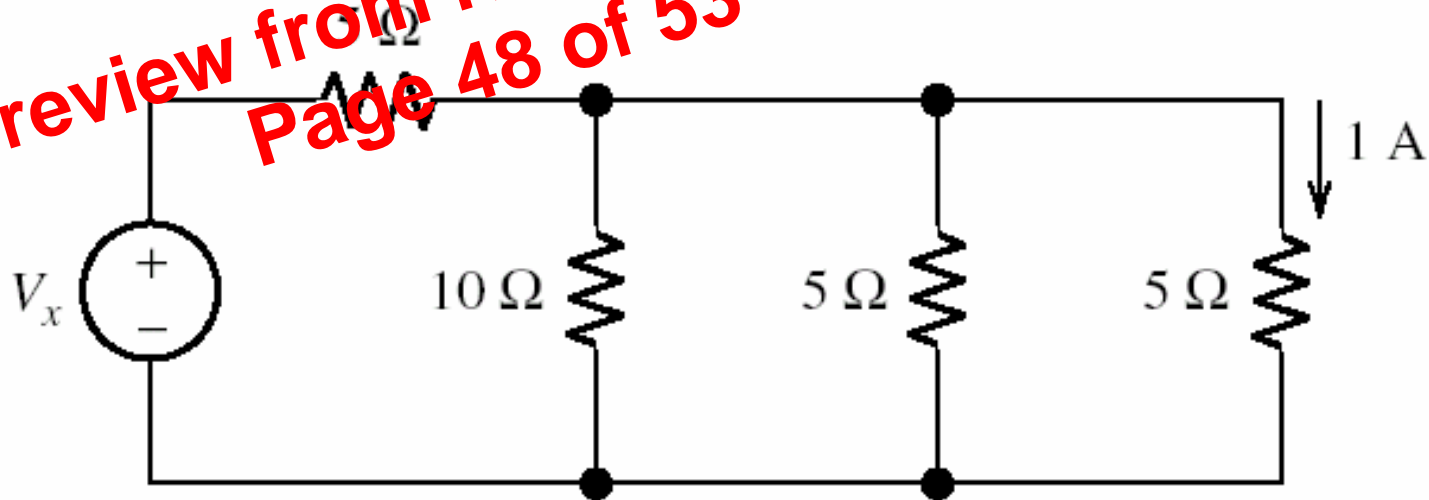

How Many KCL or KVL Equations are Needed?

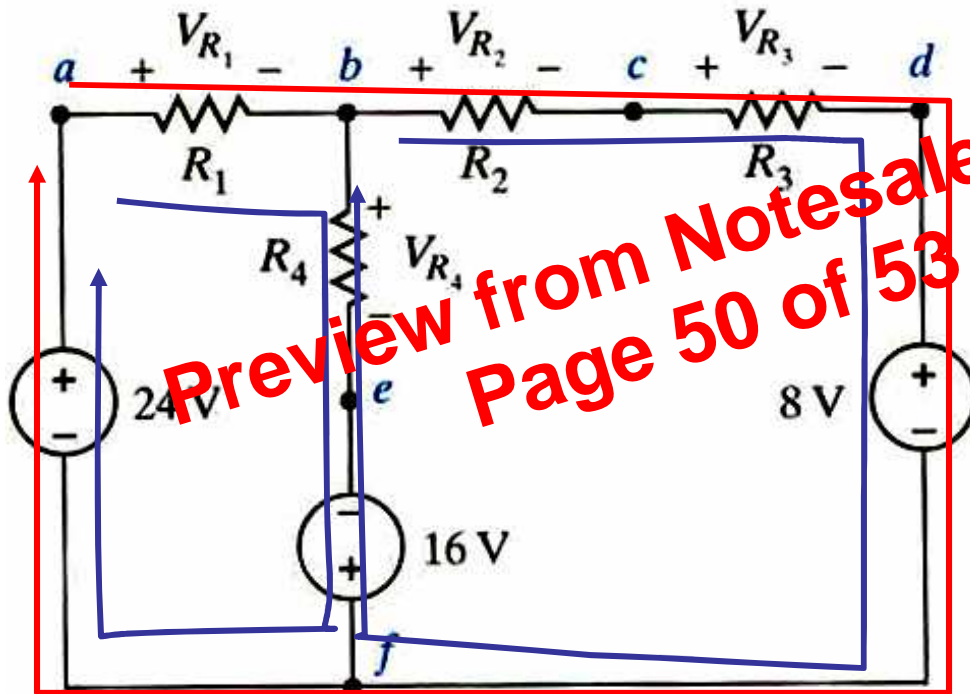

In the circuit define

N Number of nodes
 B Number of branches

$N-1$ Linearly Independent KCL Equations
 $B-(N-1)$ Linearly Independent KVL Equations

Preview from Notesale.co.uk
 Page 50 of 53

$$V_{R_1} + V_{R_4} - 16 - 24 = 0$$

$$V_{R_2} + V_{R_3} + 8 + 16 - V_{R_4} = 0$$

$$V_{R_1} + V_{R_2} + V_{R_3} + 8 - 24 = 0$$

EXAMPLE:

For the circuit shown we have $N = 6$, $B = 7$. Hence there are only two independent kvl equations

The third equation is the sum of the other two!!



Another Example

Find the voltages V_{ae} & V_{ec}

Dependent sources are handled with the same ease

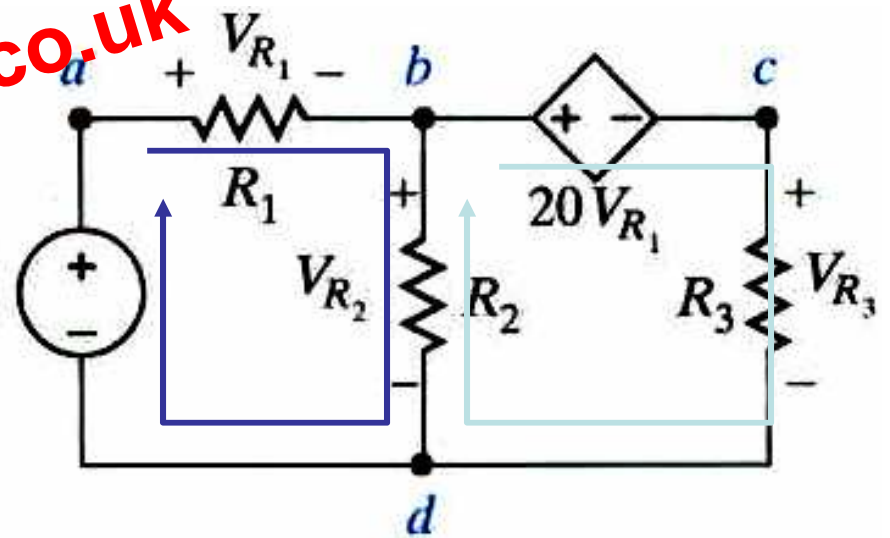
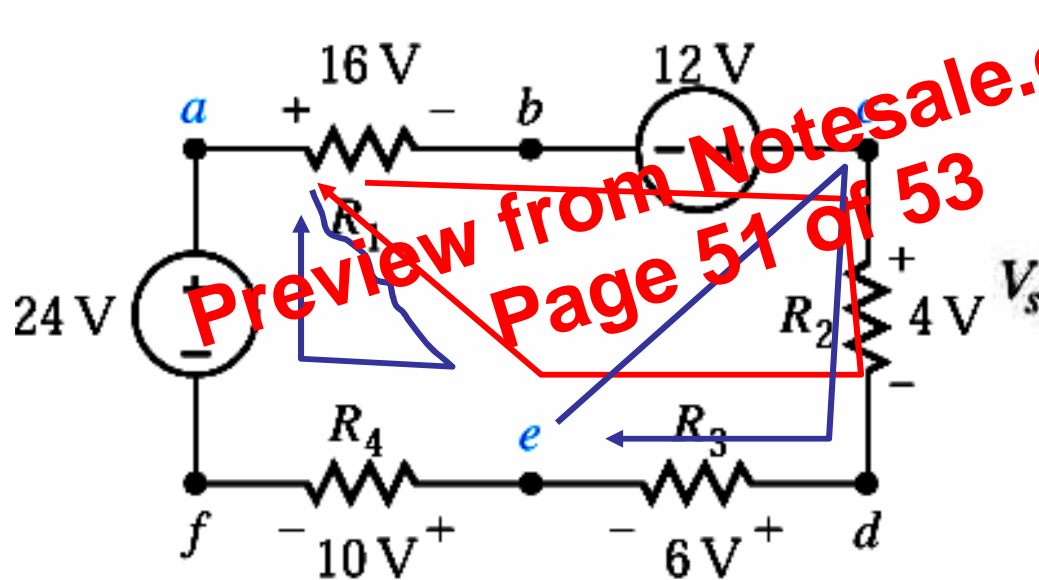

$$V_{ae} + 10 - 24 = 0$$

$$16 - 12 + 4 + 6 - V_{ae} = 0$$

Given the choice use the simplest loop

$$4 + 6 + V_{ec} = 0$$

$$V_{R_1} + V_{R_2} - V_S = 0$$

$$20V_{R_1} + V_{R_3} - V_{R_2} = 0$$