

Internal Block Diagram

- Intermediate stage (or stages) use direct coupling; provide very high gain
- Level shifter stage shifts the dc level of output voltage to zero (can be adjusted manually using two additional terminals)
- Output stage is a power amplifier stage; has very small output resistance; so output voltage is the same, no matter what is the value of load resistance connected to the output terminal

Open-loop configuration

- A_{OL} is the open-loop voltage gain of OPAMP
Its value is very high
Typical value is 0.5 million
- So, even if input is in micro volts, output will be in volts
- But output voltage cannot cross the value of power supply V_{CC}
- So, if input is in milli volts, output reaches saturation value $V_{sat} = V_{CC}$ (or V_{EE})

Open-loop configuration

- Common-mode rejection ratio
 - It is a measure of the ability of Op-Amp to reject the signals common to both input terminals (noise)
 - Defined as

$$CMRR = \frac{A_d}{A_{cm}}$$

$$(CMRR)_{dB} = 20 \log_{10} \left(\frac{A_d}{A_{cm}} \right)$$

OPAMP Characteristics

- Differential mode gain A_d
 - It is the factor by which the difference between the two input signals is amplified by the OPAMP
- Common mode gain A_{cm}
 - It is the factor by which the common mode input voltage is amplified by the OPAMP
- Common mode rejection ratio $CMRR$
 - Is the ratio of A_d to A_{cm} expressed in decibels

OPAMP Characteristics

- Output offset voltage V_{oo}
 - It is the output voltage when both input voltages are zero
 - Denoted as V_{oo}
- Input offset voltage V_{io}
 - It is the differential input voltage that must be applied at the input terminals in order to make output voltage equal to zero
 - $V_{io} = |v_1 - v_2|$ for $v_o = 0$

Difference Amplifier (Subtractor)

- The circuit is analyzed using superposition theorem
- Consider only v_1 to be present; $v_2=0$
Now derive expression for output voltage v_{o1}
- Next consider only v_2 to be present; $v_1=0$
Derive expression for output voltage v_{o2}
- Actual output voltage $v_o = v_{o1} + v_{o2}$

Integrator

Preview from Notesale.co.uk
Page 46 of 51

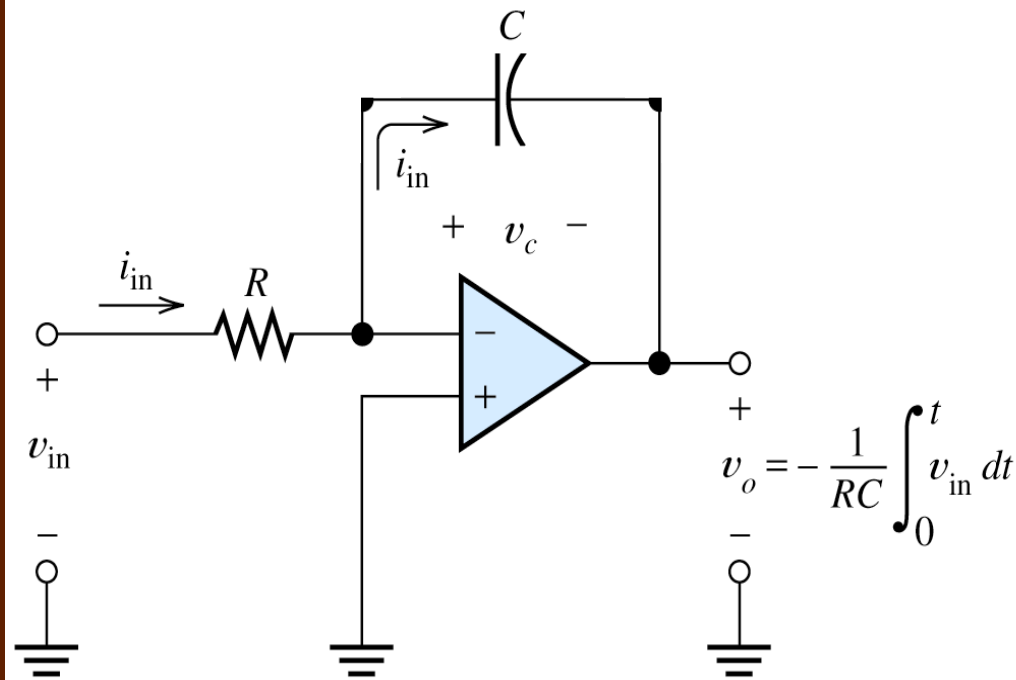

Differentiator

Preview from Notesale.co.uk
Page 49 of 51

